

**TANA**



# TANA H SERIES

LANDFILL COMPACTOR

***ECO* H320 H320**

TANA FROM WASTE TO VALUE®

# H320eco / H320

## TANA Landfill Compactor

### GENERAL INFORMATION

<b>Weight</b>	31,200 kg - 32,700 kg / 30,900 - 32,400 kg
<b>Total length</b>	8 260 mm
<b>Total width</b>	3 650 mm
<b>Total height</b>	4 410 mm
<b>Wheel base</b>	4 050 mm
<b>Ground clearance</b>	840 mm
<b>Length without dozer blade</b>	6 730 mm
<b>Width without dozer blade</b>	3 250 mm
<b>Inside turning radius</b>	3 880 mm
<b>Driving speed ranges</b>	0-4 km/h 0-10 km/h
<b>Maximum crushing force</b>	159   160 kN

### COMPACTION DRUMS

Uniform full-width drums with forged crushing teeth made of wear resistant steel. Adjustable, forged wear-resistant steel scraper bars on both sides of the drums. Adjustable, wear resistant steel wire cutters in the ends of drums.

<b>Crushing/compaction width, front drum</b>	2660 mm
<b>Crushing/compaction width, rear drum</b>	2660 mm
<b>Diameter including crushing teeth</b>	1620 mm
<b>Height of crushing teeth</b>	200 mm
<b>Number of crushing teeth, pcs (front+rear)</b>	80+80 pcs
<b>Number of scraper bars</b>	14 + 14 pcs
<b>Number of wire cutters</b>	4 + 4 pcs

### DOZER BLADE

The dozer blade is operated with two hydraulic cylinders and equipped with two arms. Arm joints are with hardened pins and spherical bearings.

<b>Width</b>	3650 mm
<b>Height</b>	1740 mm
<b>Movement above ground level</b>	1270 mm
<b>Movement below ground level</b>	150 mm

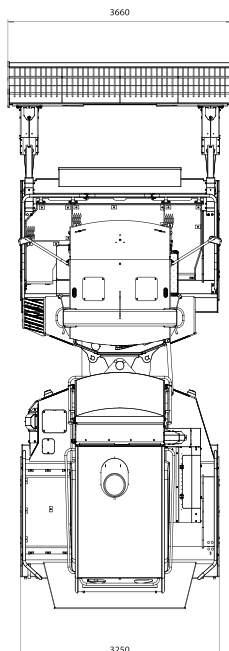

### ENGINE

#### Cummins L9-C365

- Turbo charged, 6 cylinders in line, water-cooled, after-cooled, four-stroke diesel engine
- Fulfills Tier 4 Final, EU Stage V non-road emission certificates

<b>Maximum power</b>	365 BHP(272kW)@2100 RPM
<b>Maximum torque</b>	1561 Nm (1151lb-ft) @1400 RPM
<b>Power rating</b>	365 BHP(272kW)@2100 RPM

#### Cummins QSL9-C325

- Turbo charged, 6 cylinders in line, water-cooled, after-cooled, four-stroke diesel engine
- Fulfills Tier 3, EU Stage IIIA non-road emission certificates

<b>Maximum power</b>	350 BHP(261kW)@1900 RPM
<b>Maximum torque</b>	1424 Nm (1050lb-ft) @1300-1500 RPM
<b>Power rating</b>	325 BHP(242kW)@2100 RPM

### Engine equipment

- Dry type air cleaner with replaceable primary and safety element
- Service indicator
- Fuel filter and water separator 1 pc
- Oil filter 1 pc
- Radiator + separate charge air cooler
- Starter motor 24V
- Alternator 24V, 110A

### FRAME

The frame is constructed of two modular drum frames connected together with a longitudinal upper frame. The drum frame acts as a shell around the drum, which helps to prevent waste raising to the upper parts of the machine from below.

The upper frame is equipped with center point articulated steering operated with two hydraulic cylinders.

- Articulation links are equipped with hardened pins and spherical steel bearings
- The angle of articulation to the left or right is 40 degrees

### SERVICE PLATFORMS AND PROTECTION

Service platforms and steps are equipped with banisters and anti-slide surface. Engine and powerpack are protected with lockable hood (bonnet). Opening of hood is made easier by using wind hooks.

### VANDALISM PROTECTION

- Lockable cabin, engine compartment and fuel tank filling cap
- Electronic key for ignition

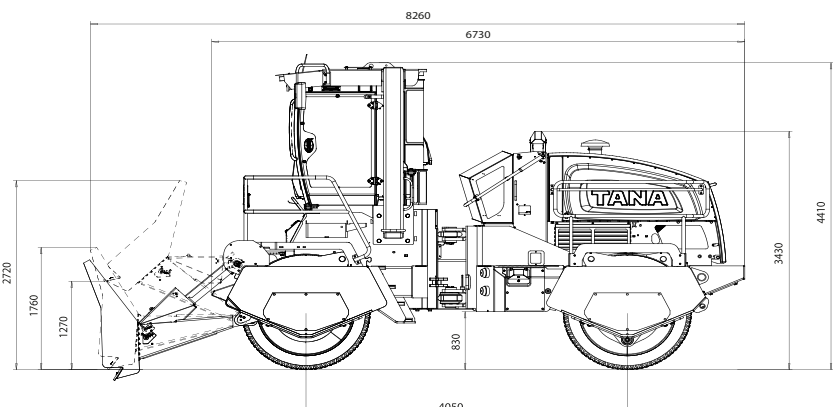

## CABIN AND CONTROLS

### Equipment

- Pressurized, heat and sound insulated cabin with cabin lights
- Insulation materials in accordance with ISO 3795
- Laminated safety glass windows
- Socket for mobile phone charger, radio with CD/MP3 player
- Front and rear windshield intermittent wipers and washers, sun cover in front
- Heater and A/C unit
- Emergency exit, lockable door, shelf and lockers, external rear view mirrors, inside mirror
- Replaceable cabin air filters in accordance with EUROVENT

### Gauges included in TANA Control System (TCS)

- Engine oil pressure, engine intake air temperature, engine oil and hydraulic oil temperatures, engine coolant temperature
- Final drive gearbox temperatures
- Fuel level, total fuel consumption
- Voltage, tachometer, boost pressure, engine working hours
- Engine load rate



Spacious cabin with excellent visibility for operational safety & efficiency.



High resolution color touch screen for easy operation.

### Controls

- Transmission and parking brake on/off
- Traction control
- Emergency stop
- Start/Stop switch: power on/off, start/stop
- Heater and air conditioning, cabin temperature control
- Windshield wipers and washers
- Headlights
- Additional lights
- Windshield wipers and washers

### Joystick controls integrated in arm-rests

- Return to neutral position automatically when released and all related movements will stop
- Left hand joystick for control of driving speed and direction as well as control of optional bucket/accessory control, speed range selection by pressing a button, horn
- Right hand joystick for control of steering and dozer blade

### System warnings in TCS

(indicator light, acoustic warning and alarm log)

- Engine over speed
- Hydraulic oil temperature (both high and low)
- Low hydraulic oil level
- High hydraulic oil contamination
- Fuel level
- Gear box temperature (both high and low)
- Hydraulic oil return line filter clogging
- Charge pressure filter contamination
- Low charge pressure
- Voltage (both high and low)
- In addition to above all the alarms from the diesel engine control module (including low engine oil pressure, high coolant temperature, etc).

### ROPS / FOPS

#### Integrated in cabin structure

- ROPS in accordance with ISO 3471:2008
- FOPS in accordance with ISO 3449:2005

Weights and measurements are given within normal tolerances. Manufacturer reserves the right to alter the above as necessary. Some features shown may be optional and not standard.



# H320eco / H320

## TANA Landfill Compactor

### POWER TRANSMISSION

- Closed circuit, hydrostatic transmission
- Separate systems for both drums
- Two driving speed ranges
- Control of driving speed and direction with one lever
- Stepless speed control

### Pumps

- One tandem pump arrangement
- Variable displacement axial piston pumps with electrical proportional control

### Motors

- Two variable displacement plug-in motors

### Cooling of hydraulic system

- Air-operated oil cooler
- Openable air filtration screen

### Hydraulic oil filtration

- Return line filter and two charge pressure filters
- Hydraulic oil filling filter

### Final drive gearboxes

- Transmits hydraulic output to the drums
- Three-stage planetary gearboxes (2 pcs)
- Integrated hydraulic oil pressure released multiplate parking brake
- Splash lubrication system

### BRAKES

- Service brakes: hydrostatic transmission acts as service brakes, separate circuits for both drums
- Parking/emergency brakes: hydraulic oil-released, spring-actuated multi-plate parking brake integrated in planetary gearboxes

### AUXILIARY HYDRAULICS

Open circuit system with electro-hydraulic load sensing (LS) control

### Pump

- Variable displacement axial piston pump

### Directional control valve

- Electro-hydraulic proportional control

### HYDRAULIC OIL TANK

The hydraulic oil tank is located inside the engine hood

- Electrical filling pump with automatic stop function, separate filter in oil filling connection
- Oil level sensor with alarm
- Breather filter

### FUEL TANK

Tank (capacity 655 l) is located inside the upper frame under the operator cabin

- Lockable filling cap
- Service hatch
- Suction strainer
- Drain valve
- Level sensor with alarm

### ELECTRICAL EQUIPMENT

- 24 VDC system
- Batteries 12 V 170 Ah, 2 pcs
- LED lights: front and rear light bars on the cabin roof, in addition at rear separate lights (2 pcs)
- Horn
- Socket for hand light in engine compartment
- Back-up alarm, main circuit breaker, voltage reducer for radio

## TanaConnect®

### Real-time insights. Anywhere, anytime.

#### Maximum uptime

The digital portal TanaConnect® enables real-time fleet management, keeping you consistently up-to-date.

The fleet management system collects, analyses, and presents data from your TANA landfill compactor to streamline operations, motivate team members, and enhance productivity. A live overview of the machine provides detailed insights into its condition and performance.



For more information, contact your local Tana distributor

**TANA**  
From Waste to Value®

Tana Oy  
P.O. Box 160,  
Schaumanin puistotie 1  
FI-40101 Jyväskylä, FINLAND

Tel. +358 20 7290 240  
mail@tana.fi  
www.tana.fi